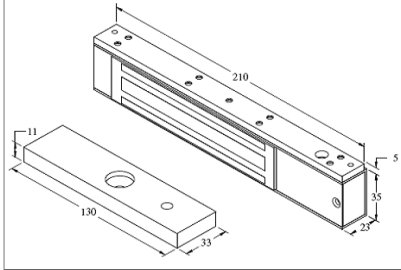
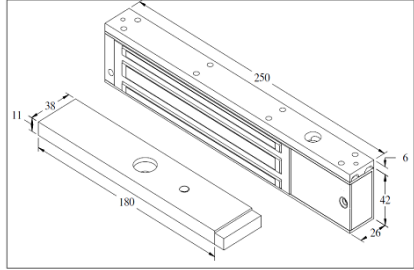
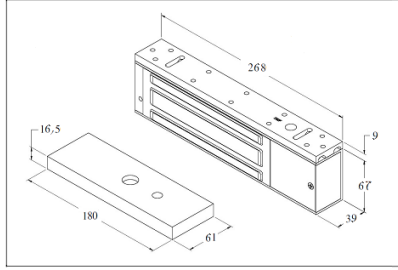
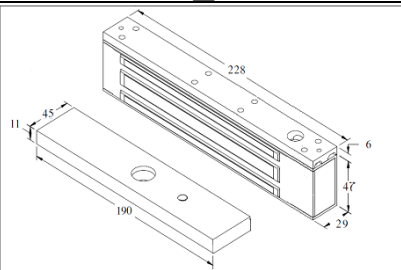
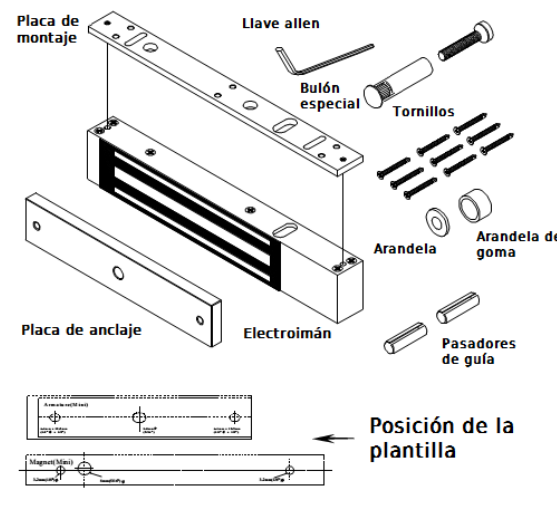

ELECTROIMÁN DE SEGURIDAD INSTRUCCIONES PARA LA INSTALACIÓN TIPO E D T

EDT 150_001	EDT 300_001...003	EDT 500_001
		
EDT 35W_000...001		
		

Quote in mm

CONTENIDO DE L EMBALAJE

	DESCRIPCIÓN	EDT150	EDT300	EDT500
		ctd	ctd	ctd
	Electroimán	1	1	1
	Placa de anclaje	1	1	1
	Placa de montaje	1	1	1
	Tornillo 3,2x18 mm	10	10	-
	Tornillo 4x25 mm	-	-	12
	Pasadores de guía 4x12 mm	2	2	2
	Bulón especial	1	1	1
	Llave allen 3 mm	1	1	-
	Llave allen 5 mm	-	-	1
	Arandela de acero	1	1	1
	Arandela de goma	1	1	1

Note: Antes de la instalación compruebe que los tornillos son adecuados para la superficie de montaje.

INSTALACIONES TÍPICAS EN LAS PUERTAS BATIENTES

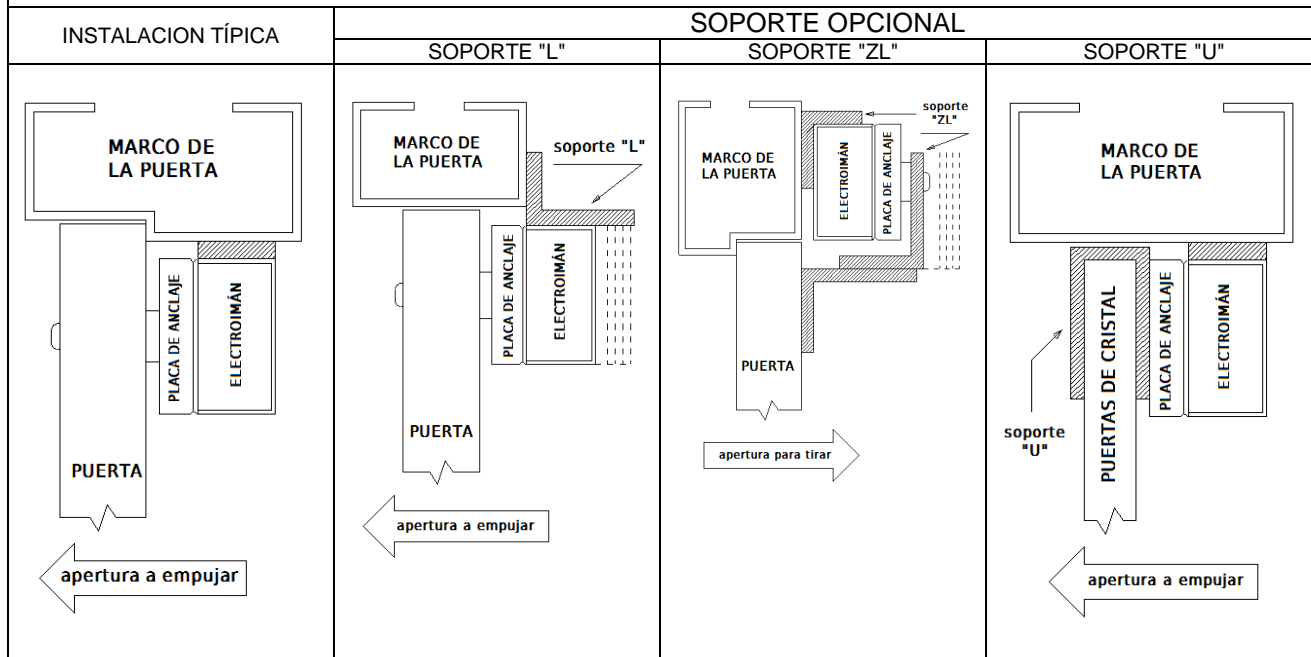

ESPECIFICACIONES TÉCNICAS

TIPO	FUERZA DE RETENCIÓN		ALIMENTACIÓN				USO
	Kg	N	Vdc	mA	Vdc	mA	
EDT150	150	1470	12	380	24	215	PUERTAS BATIENTES
EDT300	300	2940		530		290	
EDT35W	350	3430		480		240	
EDT500	500	4900		450		255	

CONEXIONES ELÉCTRICAS

